



**Elevator  
Equipment  
Corporation**

## **TS-2002 Tape Selector Landing System**



The model TS-2002 Tape Selectors from Elevator Equipment Corporation represents the next generation of elevator landing systems.

Intended to replace older mechanical hoistway switches and bulky landing boxes, the EECO TS-2002 is designed for ease of installation and adjustment. The EECO Tape Selector is quality engineered and proudly manufactured in the USA and is ASME A17.1 compliant.

The tape selector box uses an array of magnetic sensors to provide accurate car control throughout the travel. The selector box attaches to the car cross head and moves along a three inch wide steel tape. LED display on outside cover indicates sensor operation.

The steel tape is mounted at the top and bottom of the hoistway. A series of magnetic strips are attached to the tape and are used to activate the magnetic sensors in the selector box. The position of these magnets define the LU, LD, DZ, STD and STU for each floor. The available options include rear entrances, short floor and access zoning. Contact EECO for more information.

The selector box glides freely along the steel tape using four Delrin tape guides. These Delrin guides are designed for long life and easy replacement. The TS-2002 is designed to handle both hydraulic and traction elevators.

### ***TS-2002 Features***

**Compatible With All Solid State Controllers\***

**Fast Installation**

**Easy Floor Leveling Adjustment**

**State-Of-The-Art Design**

**High Durability**

**Solid State Circuitry With LED Indicators**

\*For Compatibility with older relay controllers contact EECO engineering.





Elevator Equipment Corporation

4035 Goodwin Avenue, Los Angeles, CA 90039 - (800) 423-2800  
2230 N.W. 12th Street, Richmond, IN 47374 - (800) 428-6564  
LA Fax: (323) 245-9771 - Richmond IN Fax: (765) 966-7299  
www.elevatorequipment.com  
www.eecovalves.com

# TS-2002 Tape Selector Landing System

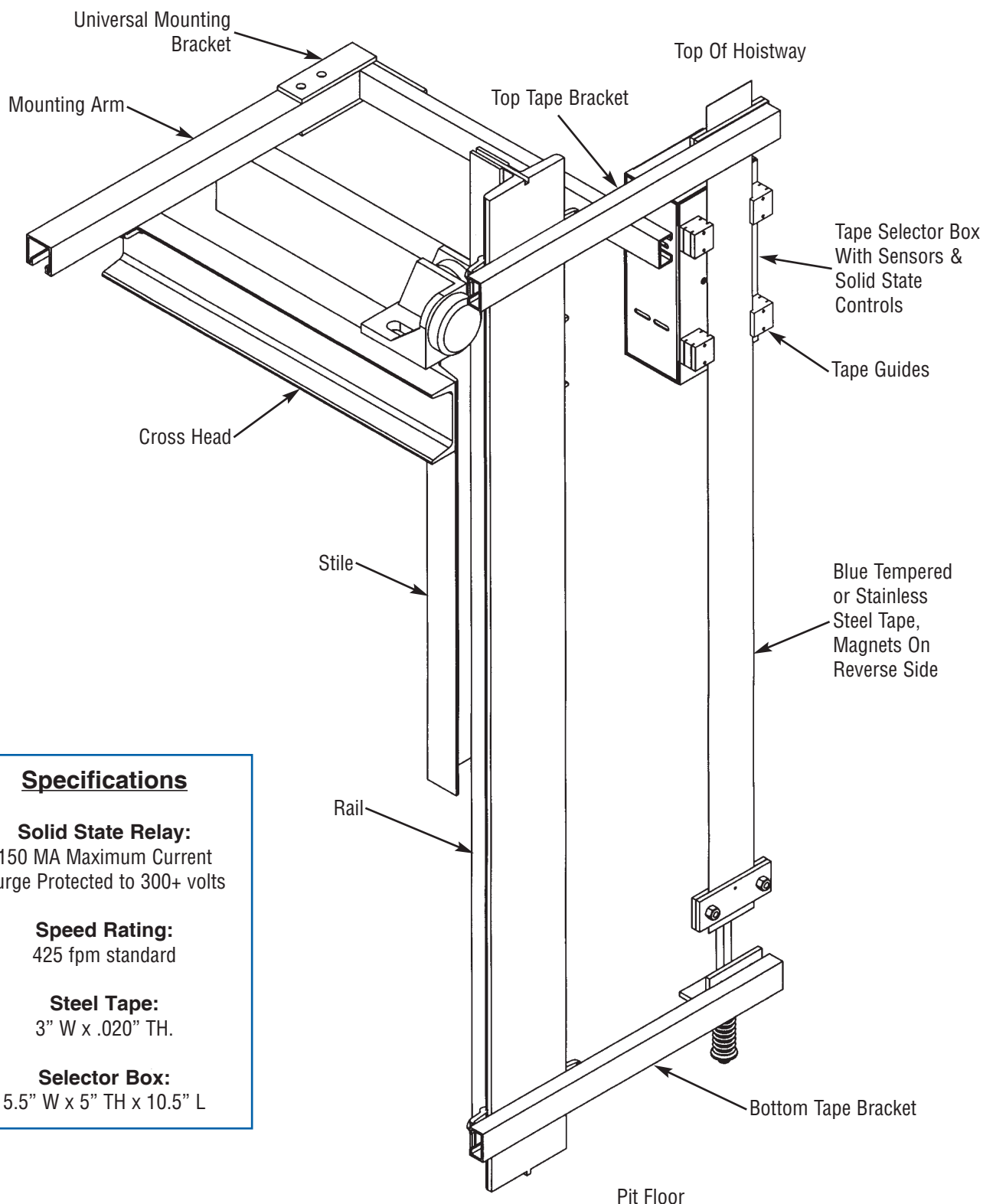

## Specifications

**Solid State Relay:**  
150 MA Maximum Current  
Surge Protected to 300+ volts

**Speed Rating:**  
425 fpm standard

**Steel Tape:**  
3" W x .020" TH.

**Selector Box:**  
5.5" W x 5" TH x 10.5" L

To order, or for additional information, please call us at: **(888) 577-EECO (3326)**

Visit us on the web at: [www.elevatorequipment.com](http://www.elevatorequipment.com) and [www.eecovalves.com](http://www.eecovalves.com). Call us toll free at (888) 577-EECO (3326)